



MOTOROLA

Order this document by LM393/D

LM393, LM393A, LM293, LM2903, LM2903V

Low Offset Voltage Dual Comparators

The LM393 series are dual independent precision voltage comparators capable of single or split supply operation. These devices are designed to permit a common mode range-to-ground level with single supply operation. Input offset voltage specifications as low as 2.0 mV make this device an excellent selection for many applications in consumer automotive, and industrial electronics.

- Wide Single-Supply Range: 2.0 Vdc to 36 Vdc
- Split-Supply Range: ± 1.0 Vdc to ± 18 Vdc
- Very Low Current Drain Independent of Supply Voltage: 0.4 mA
- Low Input Bias Current: 25 nA
- Low Input Offset Current: 5.0 nA
- Low Input Offset Voltage: 2.0 mV (max) LM393A
5.0 mV (max) LM293/393
- Input Common Mode Range to Ground Level
- Differential Input Voltage Range Equal to Power Supply Voltage
- Output Voltage Compatible with DTL, ECL, TTL, MOS, and CMOS Logic Levels
- ESD Clamps on the Inputs Increase the Ruggedness of the Device without Affecting Performance

SINGLE SUPPLY, LOW POWER DUAL COMPARATORS

SEMICONDUCTOR TECHNICAL DATA

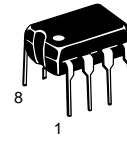

N SUFFIX
PLASTIC PACKAGE
CASE 626

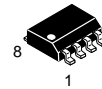

D SUFFIX
PLASTIC PACKAGE
CASE 751
(SO-8)

Representative Schematic Diagram

(Diagram shown is for 1 comparator)

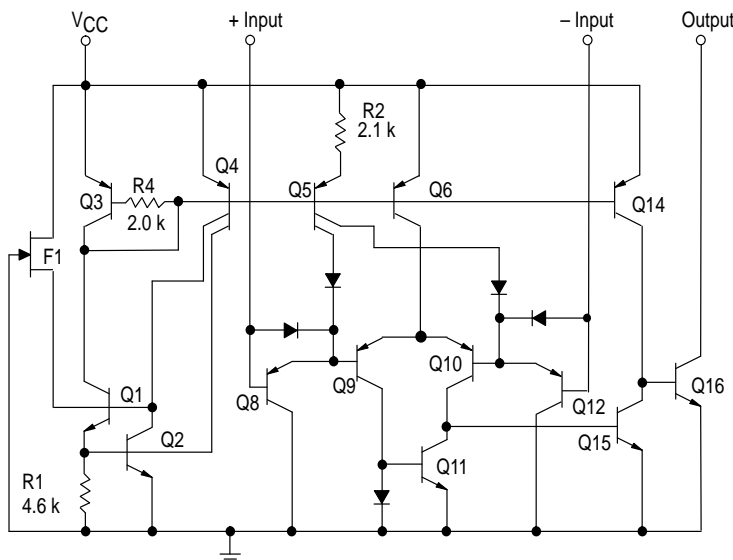

PIN CONNECTIONS

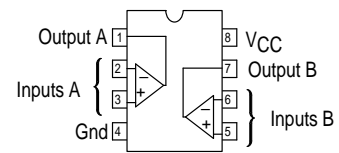

(Top View)

ORDERING INFORMATION

Device	Operating Temperature Range	Package
LM293D	$T_A = -25^\circ$ to $+85^\circ\text{C}$	SO-8
LM393D	$T_A = 0^\circ$ to $+70^\circ\text{C}$	SO-8
LM393AN,N		Plastic DIP
LM2903D	$T_A = -40^\circ$ to $+105^\circ\text{C}$	SO-8
LM2903N		Plastic DIP
LM2903VD	$T_A = -40^\circ$ to $+125^\circ\text{C}$	SO-8
LM2903VN		Plastic DIP

LM393, LM393A, LM293, LM2903, LM2903V

MAXIMUM RATINGS

Rating	Symbol	Value	Unit
Power Supply Voltage	V_{CC}	+36 or ± 18	Vdc
Input Differential Voltage Range	V_{IDR}	36	Vdc
Input Common Mode Voltage Range	V_{ICR}	-0.3 to +36	Vdc
Output Short Circuit-to-Ground Output Sink Current (Note 1)	I_{SC} I_{Sink}	Continuous 20	mA
Power Dissipation @ $T_A = 25^\circ\text{C}$ Derate above 25°C	P_D $1/R_{\theta JA}$	570 5.7	mW mW/ $^\circ\text{C}$
Operating Ambient Temperature Range LM293 LM393, 393A LM2903 LM2903V	T_A	-25 to +85 0 to +70 -40 to +105 -40 to +125	$^\circ\text{C}$
Maximum Operating Junction Temperature LM393, 393A, 2903, LM2903V LM293	$T_{J(max)}$	125 150	$^\circ\text{C}$
Storage Temperature Range	T_{stg}	-65 to +150	$^\circ\text{C}$

ELECTRICAL CHARACTERISTICS ($V_{CC} = 5.0$ Vdc, $T_{low} \leq T_A \leq T_{high}$, * unless otherwise noted.)

Characteristic	Symbol	LM393A			Unit
		Min	Typ	Max	
Input Offset Voltage (Note 2) $T_A = 25^\circ\text{C}$ $T_{low} \leq T_A \leq T_{high}$	V_{IO}	- -	± 1.0 -	± 2.0 4.0	mV
Input Offset Current $T_A = 25^\circ\text{C}$ $T_{low} \leq T_A \leq T_{high}$	I_{IO}	- -	± 50 -	± 50 ± 150	nA
Input Bias Current (Note 3) $T_A = 25^\circ\text{C}$ $T_{low} \leq T_A \leq T_{high}$	I_{IB}	- -	25 -	250 400	nA
Input Common Mode Voltage Range (Note 4) $T_A = 25^\circ\text{C}$ $T_{low} \leq T_A \leq T_{high}$	V_{ICR}	0 0	- -	$V_{CC} - 1.5$ $V_{CC} - 2.0$	V
Voltage Gain $R_L \geq 15$ k Ω , $V_{CC} = 15$ Vdc, $T_A = 25^\circ\text{C}$	A_{VOL}	50	200	-	V/mV
Large Signal Response Time $V_{in} = \text{TTL Logic Swing}$, $V_{ref} = 1.4$ Vdc $V_{RL} = 5.0$ Vdc, $R_L = 5.1$ k Ω , $T_A = 25^\circ\text{C}$	-	-	300	-	ns
Response Time (Note 5) $V_{RL} = 5.0$ Vdc, $R_L = 5.1$ k Ω , $T_A = 25^\circ\text{C}$	t_{TLH}	-	1.3	-	μs
Input Differential Voltage (Note 6) All $V_{in} \geq \text{Gnd}$ or V^- Supply (if used)	V_{ID}	-	-	V_{CC}	V
Output Sink Current $V_{in} \geq 1.0$ Vdc, $V_{in+} = 0$ Vdc, $V_O \leq 1.5$ Vdc, $T_A = 25^\circ\text{C}$	I_{Sink}	6.0	16	-	mA
Output Saturation Voltage $V_{in} \geq 1.0$ Vdc, $V_{in+} = 0$ Vdc, $I_{Sink} \leq 4.0$ mA, $T_A = 25^\circ\text{C}$ $T_{low} \leq T_A \leq T_{high}$	V_{OL}	- -	150 -	400 700	mV

* $T_{low} = 0^\circ\text{C}$, $T_{high} = +70^\circ\text{C}$ for LM393/393A

- NOTES:**
- The maximum output current may be as high as 20 mA, independent of the magnitude of V_{CC} ; output short circuits to V_{CC} can cause excessive heating and eventual destruction.
 - At output switch point, $V_O = 1.4$ Vdc, $R_S = 0$ Ω with V_{CC} from 5.0 Vdc to 30 Vdc, and over the full input common mode range (0 V to $V_{CC} = -1.5$ V).
 - Due to the PNP transistor inputs, bias current will flow out of the inputs. This current is essentially constant, independent of the output state, therefore, no loading changes will exist on the input lines.
 - Input common mode of either input should not be permitted to go more than 0.3 V negative of ground or minus supply. The upper limit of common mode range is $V_{CC} - 1.5$ V.
 - Response time is specified with a 100 mV step and 5.0 mV of overdrive. With larger magnitudes of overdrive faster response times are obtainable.
 - The comparator will exhibit proper output state if one of the inputs becomes greater than V_{CC} ; the other input must remain within the common mode range. The low input state must not be less than -0.3 V of ground or minus supply.

LM393, LM393A, LM293, LM2903, LM2903V

ELECTRICAL CHARACTERISTICS ($V_{CC} = 5.0$ Vdc, $T_{low} \leq T_A \leq T_{high}$,* unless otherwise noted.)

Characteristic	Symbol	LM393A			Unit
		Min	Typ	Max	
Output Leakage Current $V_{in-} = 0$ V, $V_{in+} \geq 1.0$ Vdc, $V_O = 5.0$ Vdc, $T_A = 25^\circ\text{C}$ $V_{in-} = 0$ V, $V_{in+} \geq 1.0$ Vdc, $V_O = 30$ Vdc, $T_{low} \leq T_A \leq T_{high}$	I_{OL}	–	0.1	–	μA
Supply Current $R_L = \infty$ Both Comparators, $T_A = 25^\circ\text{C}$ $R_L = \infty$ Both Comparators, $V_{CC} = 30$ V	I_{CC}	–	0.4	1.0	mA
		–	1.0	2.5	

ELECTRICAL CHARACTERISTICS ($V_{CC} = 5.0$ Vdc, $T_{low} \leq T_A \leq T_{high}$, unless otherwise noted.)

Characteristic	Symbol	LM392, LM393			LM2903, LM2903V			Unit
		Min	Typ	Max	Min	Typ	Max	
Input Offset Voltage (Note 2) $T_A = 25^\circ\text{C}$ $T_{low} \leq T_A \leq T_{high}$	V_{IO}	–	± 1.0	± 5.0	–	± 2.0	± 7.0	mV
		–	–	9.0	–	9.0	15	
Input Offset Current $T_A = 25^\circ\text{C}$ $T_{low} \leq T_A \leq T_{high}$	I_{IO}	–	± 5.0	± 50	–	± 5.0	± 50	nA
		–	–	± 150	–	± 50	± 200	
Input Bias Current (Note 3) $T_A = 25^\circ\text{C}$ $T_{low} \leq T_A \leq T_{high}$	I_{IB}	–	25	250	–	25	250	nA
		–	–	400	–	200	500	
Input Common Mode Voltage Range (Note 3) $T_A = 25^\circ\text{C}$ $T_{low} \leq T_A \leq T_{high}$	V_{ICR}	0	–	$V_{CC} - 1.5$	0	–	$V_{CC} - 1.5$	V
		0	–	$V_{CC} - 2.0$	0	–	$V_{CC} - 2.0$	
Voltage Gain $R_L \geq 15$ k Ω , $V_{CC} = 15$ Vdc, $T_A = 25^\circ\text{C}$	A_{VOL}	50	200	–	25	200	–	V/mV
Large Signal Response Time $V_{in} =$ TTL Logic Swing, $V_{ref} = 1.4$ Vdc $V_{RL} = 5.0$ Vdc, $R_L = 5.1$ k Ω , $T_A = 25^\circ\text{C}$	–	–	300	–	–	300	–	ns
Response Time (Note 5) $V_{RL} = 5.0$ Vdc, $R_L = 5.1$ k Ω , $T_A = 25^\circ\text{C}$	t_{TLH}	–	1.3	–	–	1.5	–	μs
Input Differential Voltage (Note 6) All $V_{in} \geq$ Gnd or V_- Supply (if used)	V_{ID}	–	–	V_{CC}	–	–	V_{CC}	V
Output Sink Current $V_{in} \geq 1.0$ Vdc, $V_{in+} = 0$ Vdc, $V_O \leq 1.5$ Vdc, $T_A = 25^\circ\text{C}$	I_{Sink}	6.0	16	–	6.0	16	–	mA
Output Saturation Voltage $V_{in} \geq 1.0$ Vdc, $V_{in+} = 0$, $I_{Sink} \leq 4.0$ mA, $T_A = 25^\circ\text{C}$ $T_{low} \leq T_A \leq T_{high}$	V_{OL}	–	150	400	–	–	400	mV
		–	–	700	–	200	700	
Output Leakage Current $V_{in-} = 0$ V, $V_{in+} \geq 1.0$ Vdc, $V_O = 5.0$ Vdc, $T_A = 25^\circ\text{C}$ $V_{in-} = 0$ V, $V_{in+} \geq 1.0$ Vdc, $V_O = 30$ Vdc, $T_{low} \leq T_A \leq T_{high}$	I_{OL}	–	0.1	–	–	0.1	–	nA
		–	–	1000	–	–	1000	
Supply Current $R_L = \infty$ Both Comparators, $T_A = 25^\circ\text{C}$ $R_L = \infty$ Both Comparators, $V_{CC} = 30$ V	I_{CC}	–	0.4	1.0	–	0.4	1.0	mA
		–	–	2.5	–	–	2.5	

* $T_{low} = 0^\circ\text{C}$, $T_{high} = +70^\circ\text{C}$ for LM393/393A

LM293 $T_{low} = -25^\circ\text{C}$, $T_{high} = +85^\circ\text{C}$

LM2903 $T_{low} = -40^\circ\text{C}$, $T_{high} = +105^\circ\text{C}$

LM2903V $T_{low} = -40^\circ\text{C}$, $T_{high} = +125^\circ\text{C}$

- NOTES:**
- At output switch point, $V_O = 1.4$ Vdc, $R_S = 0$ Ω with V_{CC} from 5.0 Vdc to 30 Vdc, and over the full input common mode range (0 V to $V_{CC} = -1.5$ V).
 - Due to the PNP transistor inputs, bias current will flow out of the inputs. This current is essentially constant, independent of the output state, therefore, no loading changes will exist on the input lines.
 - Response time is specified with a 100 mV step and 5.0 mV of overdrive. With larger magnitudes of overdrive faster response times are obtainable.
 - The comparator will exhibit proper output state if one of the inputs becomes greater than V_{CC} , the other input must remain within the common mode range. The low input state must not be less than -0.3 V of ground or minus supply.

LM393, LM393A, LM293, LM2903, LM2903V

LM293/393,A

Figure 1. Input Bias Current versus Power Supply Voltage

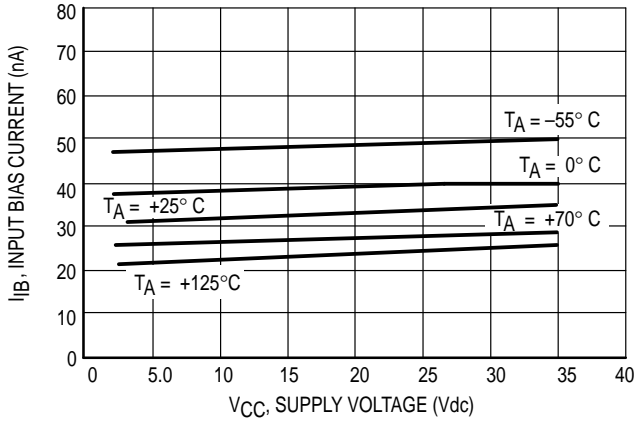

LM2903

Figure 2. Input Bias Current versus Power Supply Voltage

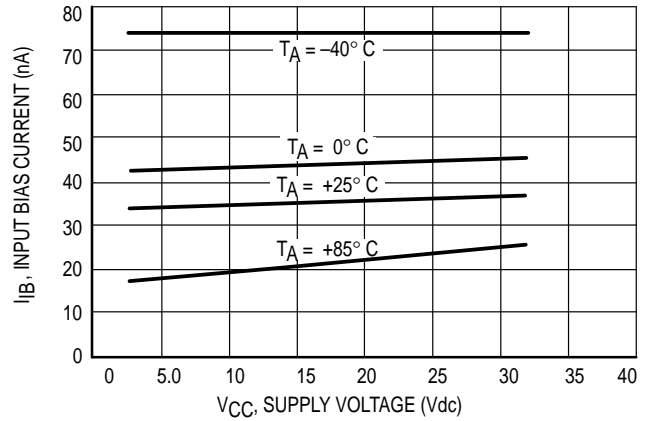

Figure 3. Output Saturation Voltage versus Output Sink Current

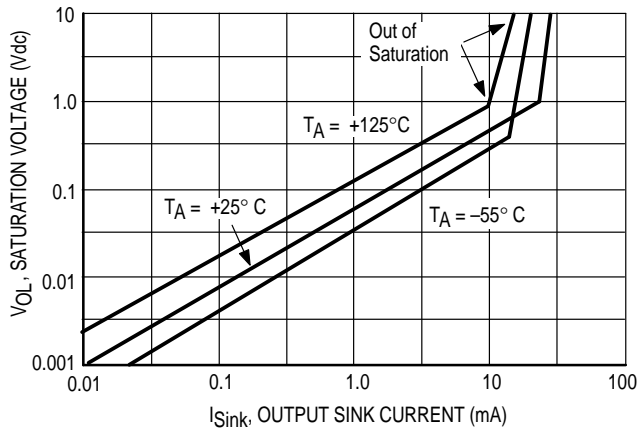

Figure 4. Output Saturation Voltage versus Output Sink Current

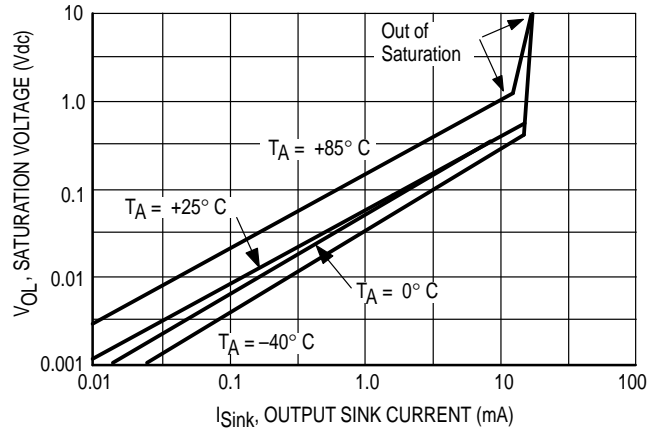

Figure 5. Power Supply Current versus Power Supply Voltage

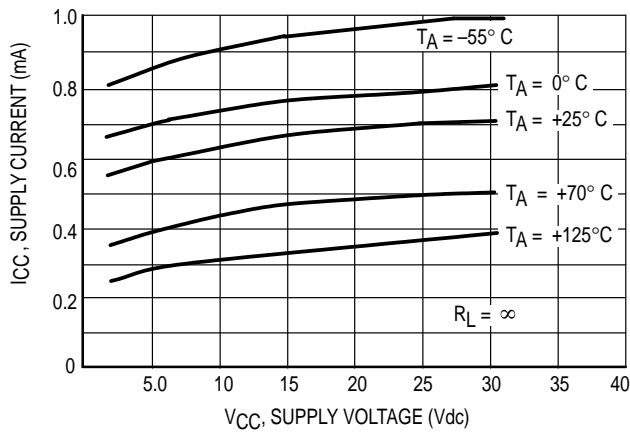
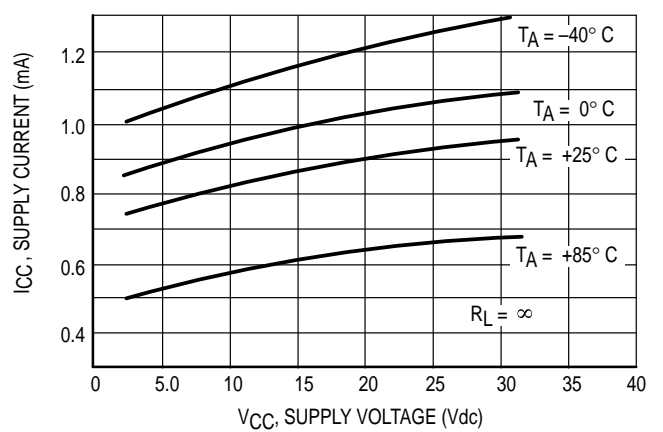

Figure 6. Power Supply Current versus Power Supply Voltage



LM393, LM393A, LM293, LM2903, LM2903V

APPLICATIONS INFORMATION

These dual comparators feature high gain, wide bandwidth characteristics. This gives the device oscillation tendencies if the outputs are capacitively coupled to the inputs via stray capacitance. This oscillation manifests itself during output transitions (V_{OL} to V_{OH}). To alleviate this situation, input resistors $< 10\text{ k}\Omega$ should be used.

The addition of positive feedback ($< 10\text{ mV}$) is also recommended. It is good design practice to ground all unused pins.

Differential input voltages may be larger than supply voltage without damaging the comparator's inputs. Voltages more negative than -0.3 V should not be used.

Figure 7. Zero Crossing Detector (Single Supply)

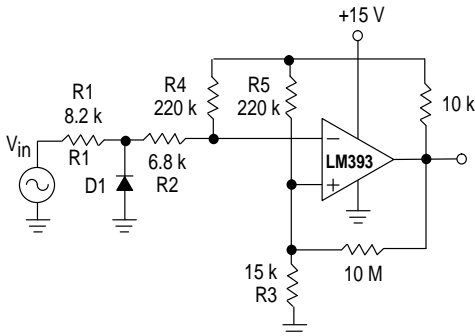

D1 prevents input from going negative by more than 0.6 V .

$$R1 + R2 = R3$$

$$R3 \leq \frac{R5}{10} \text{ for small error in zero crossing.}$$

Figure 8. Zero Crossing Detector (Split Supply)

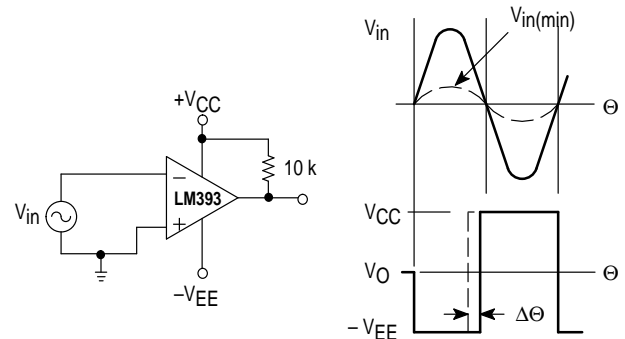

$$V_{in(\min)} \approx 0.4\text{ V peak for } 1\% \text{ phase distortion } (\Delta\Theta).$$

Figure 9. Free-Running Square-Wave Oscillator

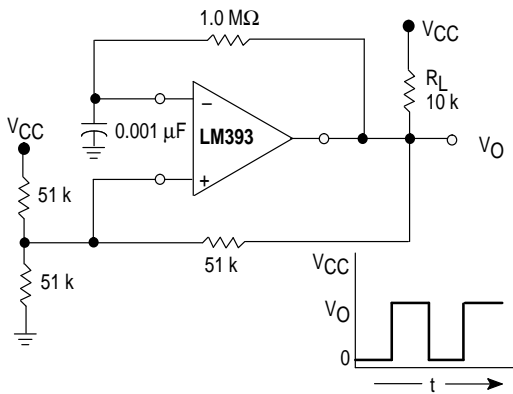
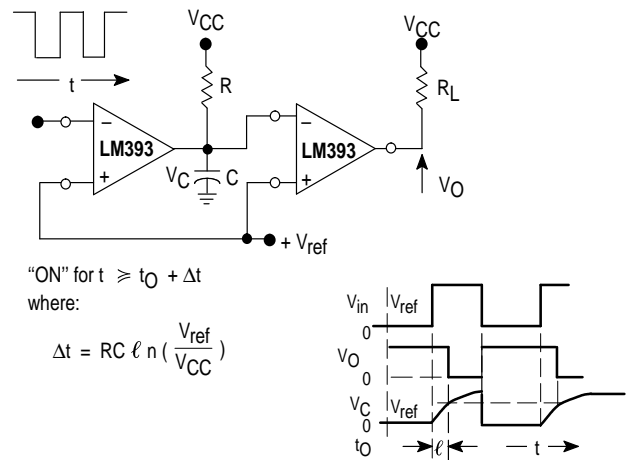

Figure 10. Time Delay Generator



"ON" for $t \geq t_0 + \Delta t$
where:

$$\Delta t = RC \ln \left(\frac{V_{ref}}{V_{CC}} \right)$$

Figure 11. Comparator with Hysteresis

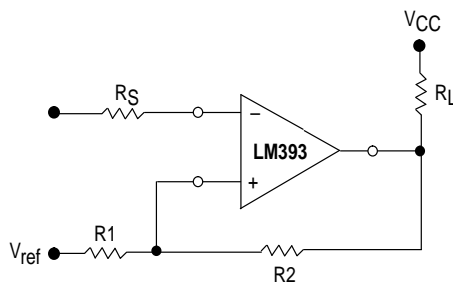

$$R_S = R1 \parallel R2$$

$$V_{th1} = V_{ref} + \frac{(V_{CC} - V_{ref}) R1}{R1 + R2 + R_L}$$

$$V_{th2} = V_{ref} - \frac{(V_{ref} - V_{OL}) R1}{R1 + R2}$$

LM393, LM393A, LM293, LM2903, LM2903V

OUTLINE DIMENSIONS

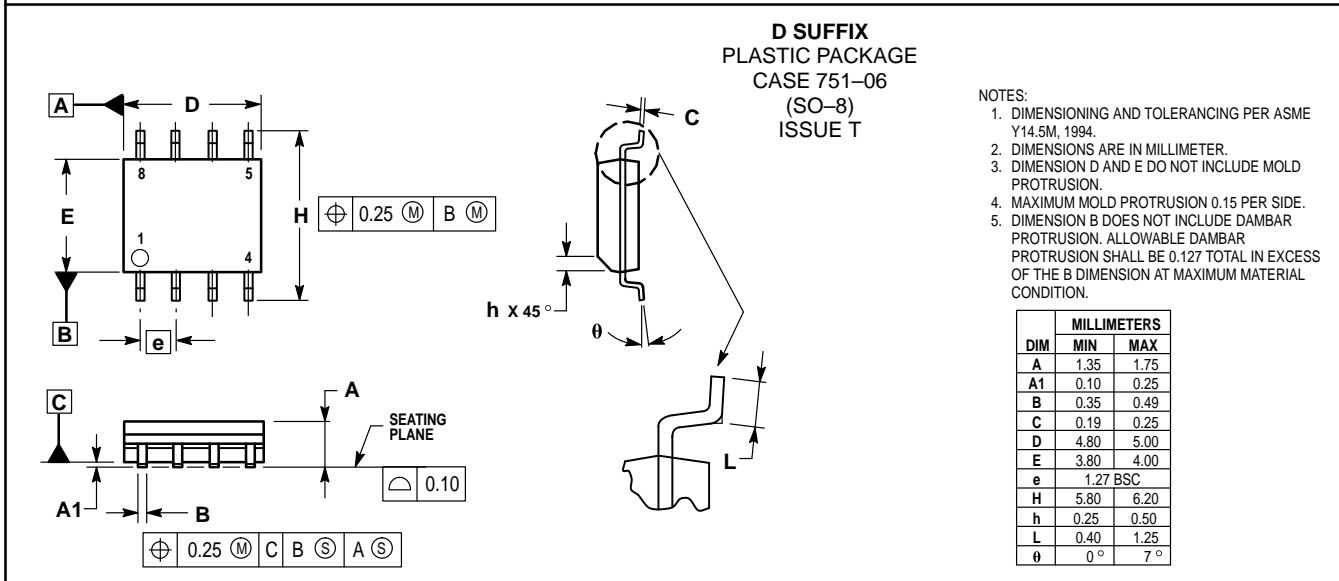
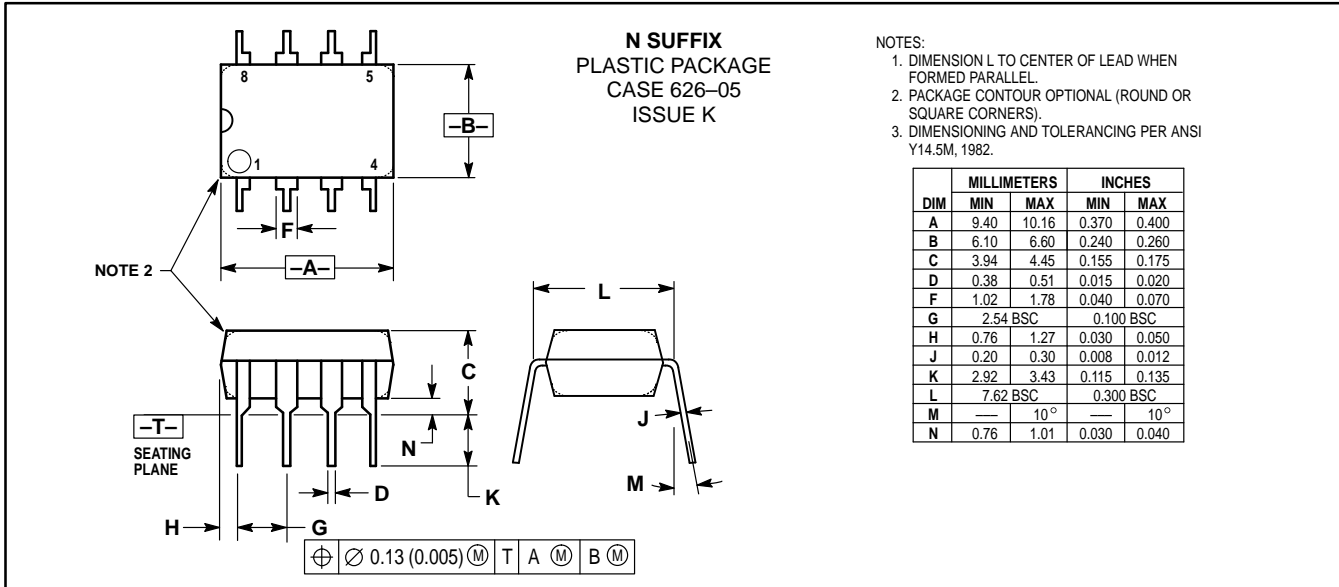

Motorola reserves the right to make changes without further notice to any products herein. Motorola makes no warranty, representation or guarantee regarding the suitability of its products for any particular purpose, nor does Motorola assume any liability arising out of the application or use of any product or circuit, and specifically disclaims any and all liability, including without limitation consequential or incidental damages. "Typical" parameters which may be provided in Motorola data sheets and/or specifications can and do vary in different applications and actual performance may vary over time. All operating parameters, including "Typicals" must be validated for each customer application by customer's technical experts. Motorola does not convey any license under its patent rights nor the rights of others. Motorola products are not designed, intended, or authorized for use as components in systems intended for surgical implant into the body, or other applications intended to support or sustain life, or for any other application in which the failure of the Motorola product could create a situation where personal injury or death may occur. Should Buyer purchase or use Motorola products for any such unintended or unauthorized application, Buyer shall indemnify and hold Motorola and its officers, employees, subsidiaries, affiliates, and distributors harmless against all claims, costs, damages, and expenses, and reasonable attorney fees arising out of, directly or indirectly, any claim of personal injury or death associated with such unintended or unauthorized use, even if such claim alleges that Motorola was negligent regarding the design or manufacture of the part. Motorola and are registered trademarks of Motorola, Inc. Motorola, Inc. is an Equal Opportunity/Affirmative Action Employer.

Mfax is a trademark of Motorola, Inc.

How to reach us:

USA/EUROPE/Locations Not Listed: Motorola Literature Distribution;
P.O. Box 5405, Denver, Colorado 80217. 1-303-675-2140 or 1-800-441-2447

JAPAN: Nippon Motorola Ltd.: SPD, Strategic Planning Office, 141,
4-32-1 Nishi-Gotanda, Shagawa-ku, Tokyo, Japan. 03-5487-8488

Customer Focus Center: 1-800-521-6274

Mfax™: RMFAX0@email.sps.mot.com – TOUCHTONE 1-602-244-6609
Motorola Fax Back System – US & Canada ONLY 1-800-774-1848
– http://sps.motorola.com/mfax/

ASIA/PACIFIC: Motorola Semiconductors H.K. Ltd.; 8B Tai Ping Industrial Park,
51 Ting Kok Road, Tai Po, N.T., Hong Kong. 852-26629298

HOME PAGE: <http://motorola.com/sps/>

